

## FEATURES

- Protected from Overvoltage Line Faults to  $\pm 60\text{V}$
- ESD Protection to IEC-1000-4-2 Level 4  
 $\pm 15\text{kV}$  Air Gap Test  
 $\pm 8\text{kV}$  Contact Mode Test
- ISO 11898 Compatible
- High Input Impedance Supports Up to 256 Nodes
- Controlled Slew Rates for EMI Emissions Control
- High Impedance Outputs When Off or Powered Down
- Short-Circuit Protection On All Outputs
- Thermal Shutdown Protection
- Pin Compatible with Philips PCA82C251

## APPLICATIONS

- Industrial Control Data Networks
- Automotive Systems
- HVAC Controls

## DESCRIPTION

The **LT<sup>®</sup>1796** CAN transceiver provides built-in fault tolerance to survive in industrial and automotive environments. Discrete protection devices are not needed. Bus interface pins can withstand voltage faults up to  $\pm 60\text{V}$  with respect to ground with no damage to the device. Faults may occur while the transceiver is active, shut down or powered off. On-chip ESD protection withstands up to  $\pm 15\text{kV}$  air discharges and  $\pm 8\text{kV}$  contact mode discharges tested per IEC-1000-4-2. Loss of power or ground connections does not damage the IC.

The circuit operates with data rates up to 125kbaud. A slew control pin allows control of transmitted data pulse edges to control EMI and reflection problems on imperfectly terminated lines. High output current drive allows the use of inexpensive PVC cable with impedance as low as  $72\Omega$ . The  $100\text{k}\Omega$  input impedance allows up to 256 transceivers per data network.

The LT1796 is available in 8-lead PDIP and SO packages.

LT, LT, LTC, LTM, Linear Technology and the Linear logo are registered trademarks of Linear Technology Corporation. All other trademarks are the property of their respective owners.

## TYPICAL APPLICATION

Fault Protected CAN Bus Network

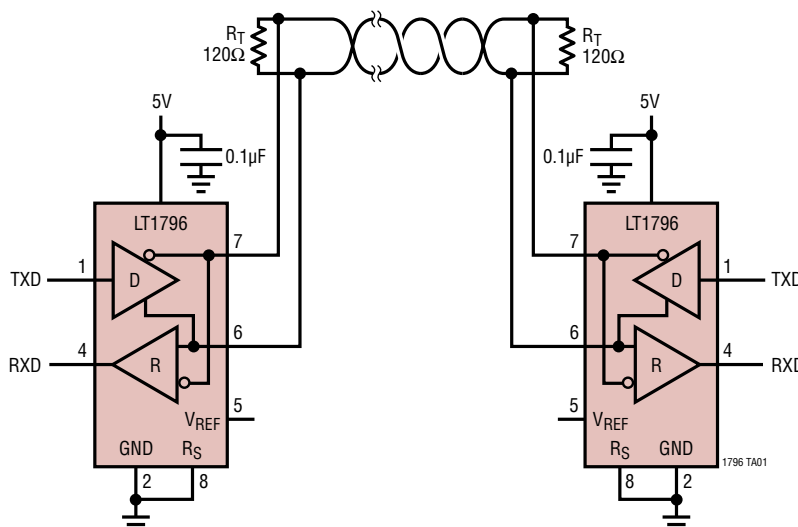

125kbps CANH and CANL Driver Output

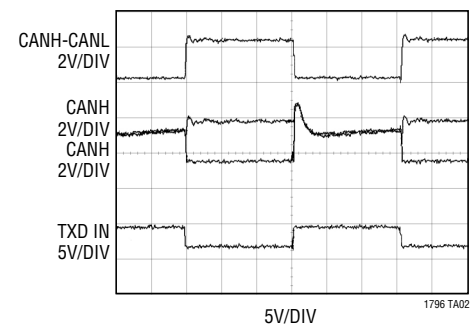

## ABSOLUTE MAXIMUM RATINGS

(Note 1)

Supply Voltage ( $V_{CC}$ ) .....	44V
$R_S$ Slope Control Input Voltage .....	-0.3V to 44V
$V_{REF}$ Reference Output Pin.....	-0.3V to 7V
Driver Input Voltage .....	-0.3V to 44V
CANH, CANL Data Line Pins.....	-80V to 80V
Receiver Output Voltages.....	-0.3V to 7V
Operating Temperature Range	
LT1796C.....	0°C to 70°C
LT1796I.....	-40°C to 85°C
Storage Temperature Range .....	-65°C to 150°C
Lead Temperature (Soldering, 10 sec).....	300°C

## PIN CONFIGURATION

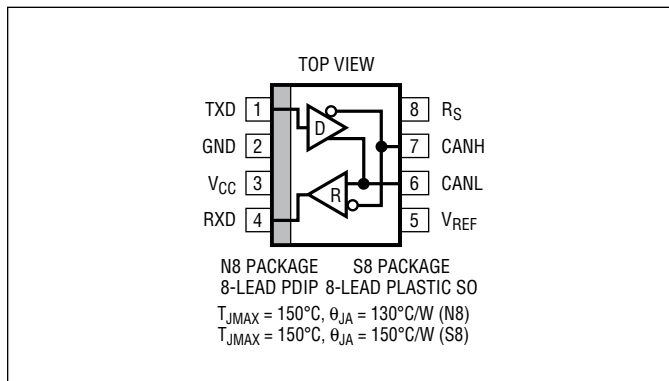

## ORDER INFORMATION

LEAD FREE FINISH	TAPE AND REEL	PART MARKING*	PACKAGE DESCRIPTION	TEMPERATURE RANGE
	LT1796CN8#TRPBF	LT1796 CN8	8-Lead PDIP	0°C to 70°C
	LT1796CS8#TRPBF	1796	8-Lead Plastic SO	0°C to 70°C
	LT1796IN8#TRPBF	LT1796I IN8	8-Lead PDIP	-40°C to 85°C
	LT1796IS8#TRPBF	1796I	8-Lead Plastic SO	-40°C to 85°C

Consult LTC Marketing for parts specified with wider operating temperature ranges. \*The temperature grade is identified by a label on the shipping container.

Consult LTC Marketing for information on nonstandard lead based finish parts.

For more information on lead free part marking, go to: <http://www.linear.com/leadfree/>

For more information on tape and reel specifications, go to: <http://www.linear.com/tapeandreeel/>

## ELECTRICAL CHARACTERISTICS

The ● denotes the specifications which apply over the full operating temperature range, otherwise specifications are at  $T_A = 25^{\circ}\text{C}$ .  $V_{CC} = 4.75\text{V}$  to  $5.25\text{V}$ ,  $V_{RS} = 0\text{V}$  unless otherwise noted.

SYMBOL	PARAMETER	CONDITIONS	MIN	TYP	MAX	UNITS	
$V_{CANH}$	CANH Output Voltage	$V_{TXD} = 0\text{V}$ , No Load	●	3.8	4.4	5.0	V
		$V_{TXD} = 0\text{V}$ , $R_L = 60\Omega$	●	2.8	3.5	4.6	V
$V_{CANL}$	CANL Output Voltage	$V_{TXD} = 0\text{V}$ , No Load	●	0	0.5	0.9	V
		$V_{TXD} = 0\text{V}$ , $R_L = 60\Omega$	●	0	1.3	1.6	V
$V_{OD}$	Dominant State Differential Output Voltage	$V_{TXD} = 0\text{V}$ , No Load, $V_{CC} = 4.75\text{V}$	●	3.0	3.6	5.0	V
		$V_{TXD} = 0\text{V}$ , $R_L = 60\Omega$ , $V_{CC} = 4.75\text{V}$	●	1.5	2.0	4.2	V
		$V_{TXD} = 0\text{V}$ , $R_L = 36\Omega$ , $V_{CC} = 4.75\text{V}$	●	1.2	1.7	4.2	V
$V_{REC}$	Recessive State Differential Output Voltage	$V_{TXD} = 5\text{V}$ , $R_L = 60\Omega$	●	-10	0	10	mV
$V_{CMR}$	Recessive State Common Mode Output Voltage	$V_{TXD} = 5\text{V}$ , $R_L = 60\Omega$ , $V_{CC} = 5\text{V}$	●	2.7	3	3.5	V

**ELECTRICAL CHARACTERISTICS** The ● denotes the specifications which apply over the full operating temperature range, otherwise specifications are at  $T_A = 25^\circ\text{C}$ .  $V_{CC} = 4.75\text{V}$  to  $5.25\text{V}$ ,  $V_{RS} = 0\text{V}$  unless otherwise noted.

SYMBOL	PARAMETER	CONDITIONS	MIN	TYP	MAX	UNITS
$V_{CMD}$	Dominant State Common Mode Output Voltage	$R_L = 60\Omega$ , $V_{CC} = 5\text{V}$	● 2	2.5	3	V
$V_{IH}$	TXD Input High Voltage		● 2.8			V
$V_{IL}$	TXD Input Low Voltage				2	V
$I_{IN1}$	TXD Input Current	$0 < V_{TXD} < V_{CC}$	● -5		5	$\mu\text{A}$
$I_{SCH}$	CANH Short-Circuit Current, Dominant Mode	$V_{CANH} = 0\text{V}$ , $V_{CC} = 5.25\text{V}$	● -250		-60	$\text{mA}$
		$V_{CANH} = -36\text{V}$ , $V_{CC} = 5.25\text{V}$	● -10	-1	0	$\text{mA}$
		$V_{CANH} = -60\text{V}$ , $V_{CC} = 5.25\text{V}$	● -10	-1	0	$\text{mA}$
		$V_{CANH} = 60\text{V}$ , $V_{CC} = 5.25\text{V}$	● 0	1	10	$\text{mA}$
$I_{SCL}$	CANL Short-Circuit Current, Dominant Mode	$V_{CANL} = 5\text{V}$ , $V_{TXD} = 0\text{V}$ , $V_{CC} = 5.25\text{V}$	● 60		250	$\text{mA}$
		$V_{CANL} = 36\text{V}$ , $V_{TXD} = 0\text{V}$ , $V_{CC} = 5.25\text{V}$	● 0	1	10	$\text{mA}$
		$V_{CANL} = 60\text{V}$ , $V_{TXD} = 0\text{V}$ , $V_{CC} = 5.25\text{V}$	● 0	1	10	$\text{mA}$
		$V_{CANL} = -60\text{V}$ , $V_{TXD} = 0\text{V}$ , $V_{CC} = 5.25\text{V}$	● -10	-1	0	$\text{mA}$
$R_{IND}$	Differential Input Resistance	$V_{TXD} = 5\text{V}$ , $-7\text{V} < V_{CANH}$ , $V_{CANL} < 12\text{V}$	● 140	240	350	$\text{k}\Omega$
	CANH, CANL Input Resistance	$V_{TXD} = 5\text{V}$ , $-7\text{V} < V_{CANH}$ , $V_{CANL} < 12\text{V}$	● 70	120	175	$\text{k}\Omega$
	Input Fault Current (CANH, CANL)	$V_{RS} = 5\text{V}$ , $-60\text{V} < V_{CANH}$ , $V_{CANL} < 60\text{V}$	● -3		3	$\text{mA}$
		$V_{TXD} = 5\text{V}$ , $-60\text{V} < V_{CANH}$ , $V_{CANL} < 60\text{V}$	● -3		3	$\text{mA}$
		$V_{CC} = 0\text{V}$ , $-60\text{V} < V_{CANH}$ , $V_{CANL} < 60\text{V}$	● -3		3	$\text{mA}$

**DC ELECTRICAL CHARACTERISTICS** The ● denotes the specifications which apply over the full operating temperature range, otherwise specifications are at  $T_A = 25^\circ\text{C}$ .  $V_{CC} = 4.75\text{V}$  to  $5.25\text{V}$ ,  $V_{RS} = 0\text{V}$  unless otherwise noted.

SYMBOL	PARAMETER	CONDITIONS	MIN	TYP	MAX	UNITS
$V_{TH}$	Differential Input Threshold Voltage for Receiver	$V_{RS} = 0\text{V}$ , $-7\text{V} < V_{CM} < 12\text{V}$	● 0.5		0.9	V
		$V_{RS} = 5\text{V}$ , $-7\text{V} < V_{CM} < 12\text{V}$	● 0.5		0.9	V
$\Delta V_{TH}$	Receiver Input Hysteresis	$-7\text{V} < V_{CM} < 12\text{V}$		70		mV
$V_{OH}$	Receiver Output High Voltage	$V_{CC} = 4.75\text{V}$ , $I_O = -400\mu\text{A}$ , $V_{ID} = 500\text{mV}$	● 3	3.6		V
$V_{OL}$	Receiver Output Low Voltage	$V_{CC} = 4.75\text{V}$ , $I_O = 1.6\text{mA}$ , $V_{ID} = 900\text{mV}$	●	0.15	0.4	V
$I_{SCR}$	Receiver Short-Circuit Current	$0\text{V} < V_O < V_{CC}$ , $V_{CC} = 5.25\text{V}$	● 7	20	85	$\text{mA}$
$V_{REF}$	Reference Output Voltage	$-100\mu\text{A} < I_{REF} < 100\mu\text{A}$	● 2.25	2.5	2.7	V
$V_{REFSC}$	Reference Output Short-Circuit Current	$0 < V_{REF} < V_{CC}$	● -20		20	$\text{mA}$
$V_{RSSB}$	$R_S$ Pin Standby Threshold	$V_{CC} = 5\text{V}$	● 2.5	2.8	4	V
$I_{RS}$	$R_S$ Input Current	$V_{RS} = 5\text{V}$ , $V_{CC} = 5\text{V}$	● -270	0.1	10	$\mu\text{A}$
		$V_{RS} = 0\text{V}$ , $V_{CC} = 5\text{V}$	● -90	-200	-140	$\mu\text{A}$
		$R_S = 47\text{k}$ , $V_{CC} = 5\text{V}$	●	-60	-40	$\mu\text{A}$
$I_{CC}$	Supply Current	Dominant No Load, $V_{RS} = 0\text{V}$ , $V_{TXD} = 0\text{V}$ , $V_{CC} = 5.25\text{V}$	●	4.3	7	$\text{mA}$
		Recessive $R_L = 60\Omega$ , $V_{RS} = 0\text{V}$ , $V_{TXD} = 5\text{V}$ , $V_{CC} = 5.25\text{V}$	●	3.8	7	$\text{mA}$
		Standby $R_L = 60\Omega$ , $V_{RS} = 5\text{V}$ , $V_{CC} = 5.25\text{V}$	●	0.8	1.5	$\text{mA}$

## SWITCHING CHARACTERISTICS

The ● denotes the specifications which apply over the full operating temperature range.  $V_{RS} = 0V$  unless otherwise noted. (Note 2)

SYMBOL	PARAMETER	CONDITIONS	MIN	TYP	MAX	UNITS
$t_{BIT}$	Minimum Bit Time	(Note 3)	●		8	$\mu s$
$F_{MAX}$	Maximum Data Rate	(Note 3)	●	125		kbps
$t_{TXDON}$	Driver Input to Bus Active	Figures 1, 2	●	300	500	ns
		$R_S = 47k$	●	350	1000	ns
$t_{TXDOFF}$	Driver Input to Bus Inactive	Figures 1, 2	●	500	1200	ns
		$R_S = 47k$	●	600	1500	ns
$t_{LBON}$	Loopback Delay Active	Figures 1, 3	●	0.6	1.5	$\mu s$
$t_{LBOFF}$	Loopback Delay Inactive	Figures 1, 3	●	1.5	3	$\mu s$
$t_{RXDOFF}$	Receiver Delay Off	Figures 1, 4	●	400	600	ns
$t_{RXDON}$	Receiver Delay On	Figures 1, 4	●	300	600	ns
$t_{RXDOFFSB}$	Receiver Delay Off, Standby	$V_{RS} = 4V$ , Figures 1, 4	●	1.5	4	$\mu s$
$t_{RXDONSb}$	Receiver Delay On, Standby	$V_{RS} = 4V$ , Figures 1, 4	●	1	4	$\mu s$
$t_{WAKE}$	Wake-Up Delay from Standby	Figures 1, 5	●	1	15	$\mu s$
$SR^+$	Positive Slew Rate	$R_S = 0k$	●	5	12	$V/\mu s$
		$R_S = 47k$	●	2	7	$V/\mu s$
$SR^-$	Negative Slew Rate	$R_S = 0k$	●	5	36	$V/\mu s$
		$R_S = 47k$	●	2	5	$V/\mu s$

**Note 1:** Stresses beyond those listed under Absolute Maximum Ratings may cause permanent damage to the device. Exposure to any Absolute Maximum Rating condition for extended periods may affect device reliability and lifetime.

**Note 2:** Unless otherwise specified, testing done at  $V_{CC} = 5V$ ,  $T_A = 25^\circ C$ .

**Note 3:** Bit time and data rate specifications are guaranteed by driver and receiver delay time measurements.

## TYPICAL PERFORMANCE CHARACTERISTICS

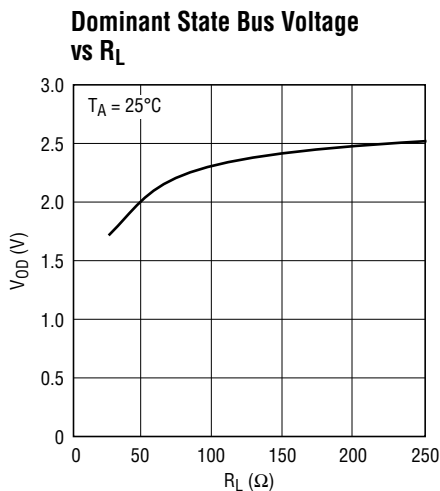

1796 G01

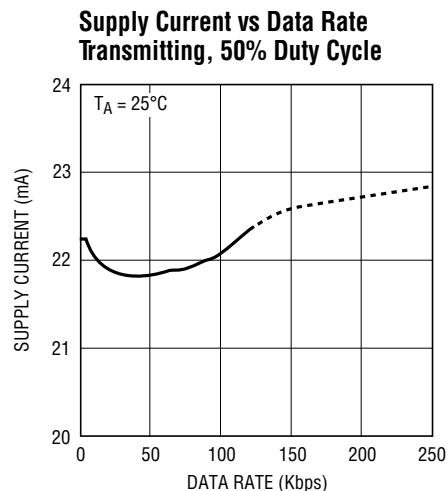

1796 G03

1796fa

# TYPICAL PERFORMANCE CHARACTERISTICS

**$R_S$  Pin Current vs  $R_S$**

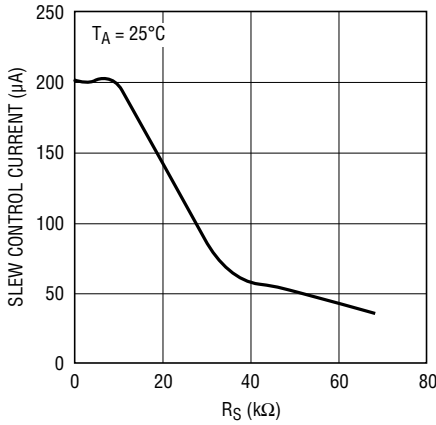

1796 G04

**Positive Slew Rate vs  $R_S$**

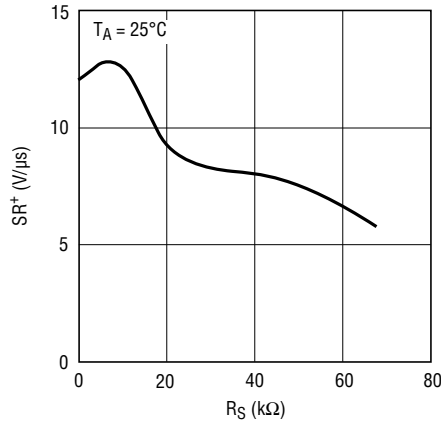

1796 G05

**Negative Slew Rate vs  $R_S$**

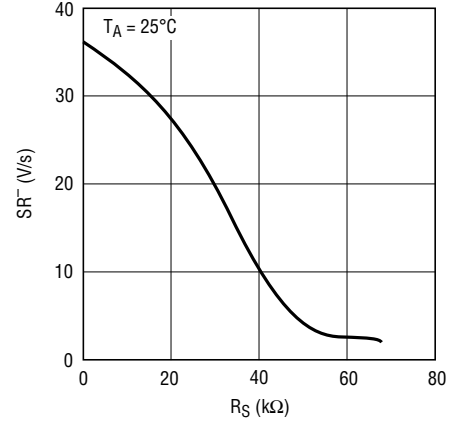

1796 G06

**Transmitter Propagation Delay vs Temperature**

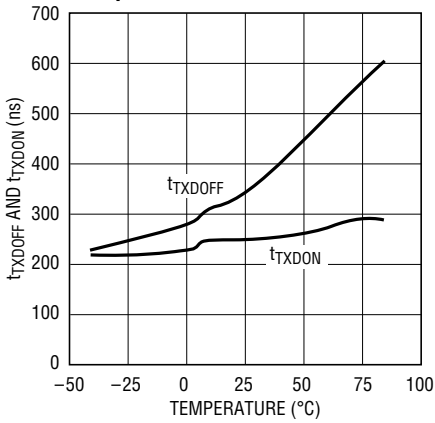

1796 G07

**CANH Short-Circuit Current vs Voltage**

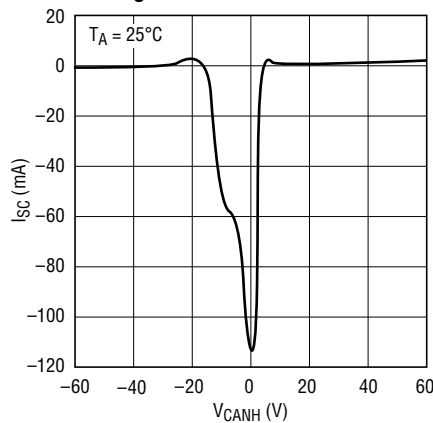

1796 G08

**CANL Short-Circuit Current vs Voltage**

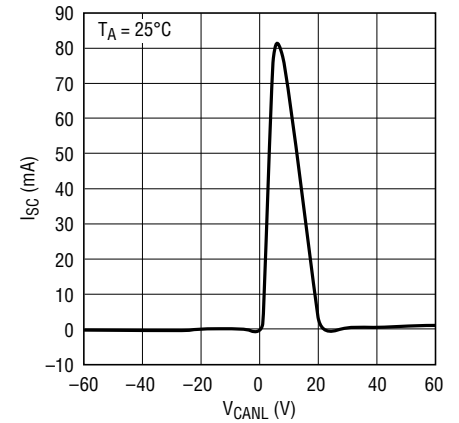

1796 G09

**Receiver Thresholds vs Temperature**

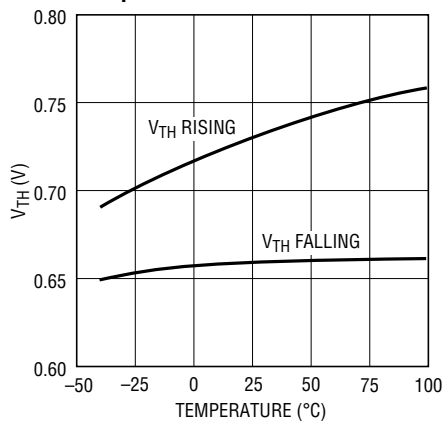

1796 G10

**Receiver Propagation Delay vs Temperature**

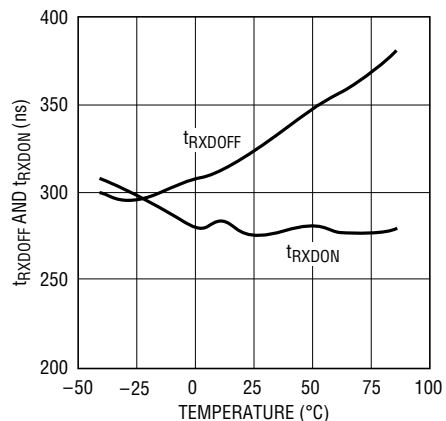

1796 G11

## PIN FUNCTIONS

**TXD (Pin 1):** Driver Input. Logic-level thresholds are set by  $V_{REF}$ . A logic input level higher than  $V_{REF}$  turns the driver outputs off, releasing control of the CANH and CANL lines. A logic input less than  $V_{REF}$  turns the driver outputs on, pulling CANH high and CANL low. An open TXD input will float high, turning the driver outputs off. The TXD input pin can withstand voltages from  $-0.3V$  to  $44V$  with no damage.

**GND (Pin 2):** Ground.

**$V_{CC}$  (Pin 3):** Positive Supply Input. Normal operation is with a  $4.75V$  to  $5.25V$  supply. Operation with supplies up to  $44V$  is possible with unterminated bus lines. Operation at high voltages with normally terminated busses will result in excessive power dissipation and activation of the thermal shutdown circuit.  $V_{CC}$  should be decoupled with a  $0.1\mu F$  low ESR capacitor placed as close to the supply pin as possible.

**RXD (Pin 4):** Receiver TTL Level-Logic Output. A high level output indicates a recessive state (zero-volt differential) bus. A dominant state forces a low receiver output.

**$V_{REF}$  (Pin 5):** Reference Output. The reference voltage sets the TXD input threshold and the recessive bus common mode voltage at CANH and CANL.  $V_{REF}$  is approximately  $V_{CC}/2$  for low voltage operation. When  $V_{CC} > 7.5V$ ,  $V_{REF}$  maintains a  $3.5V$  level.

**CANL (Pin 6):** CAN Bus Low Data Line. The CANL pin is one input to the receiver and the low driver output. In the dominant state (TXD low), the driver pulls the CANL pin to within  $1V$  of GND. In the recessive state (TXD high), the driver output stays high impedance. The CANL pin is protected from voltage faults from  $-60V$  to  $60V$  in dominant, recessive, standby or powered off modes. On-chip ESD protection meets IEC-1000-4-2 levels.

**CANH (Pin 7):** CAN Bus High Data Line. The CANH pin is one input to the receiver and the high driver output. In the dominant state (TXD low), the driver pulls the CANH pin to within  $1V$  of  $V_{CC}$ . In the recessive state (TXD high), the driver output stays high impedance. The CANH pin is protected from voltage faults from  $-60V$  to  $60V$  in dominant, recessive, standby or powered off modes. On-chip ESD protection meets IEC-1000-4-2 levels.

**$R_S$  (Pin 8):** Slope Control. This pin is a multifunction control pin. When  $R_S$  is high ( $V_{RS} > 4V$ ), the circuit goes into a low power standby mode. In standby, the driver always stays in a high impedance (recessive) state. The receiver operates in a low power (slow) monitoring mode. Received data may be used to “wake-up” the system to full functionality. Full speed normal operation occurs if  $R_S$  is tied low through a resistance of less than  $3k$ . The current out of  $R_S$  will be limited to about  $500\mu A$  in the low state. Controlling the current out of  $R_S$  with a resistor greater than  $3k$  or by using a current source allows slew rate control of the data output onto CANH and CANL.

## BLOCK DIAGRAM

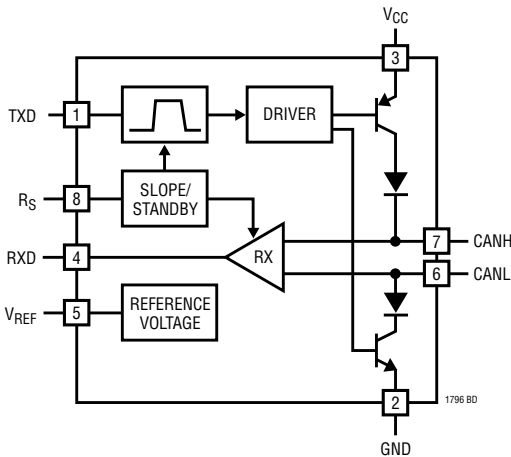

## TEST CIRCUIT

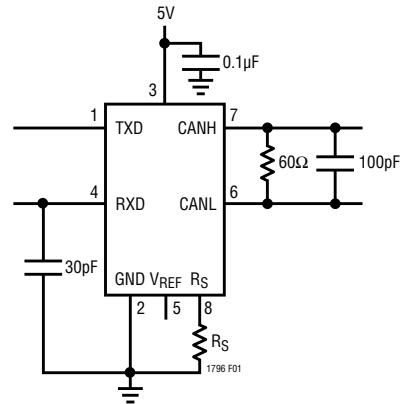

Figure 1. Switching Test Circuit

## TIMING DIAGRAM

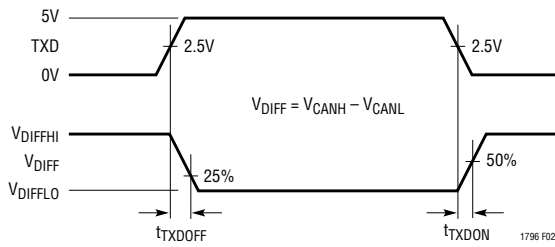

Figure 2. Driver Delay Waveforms

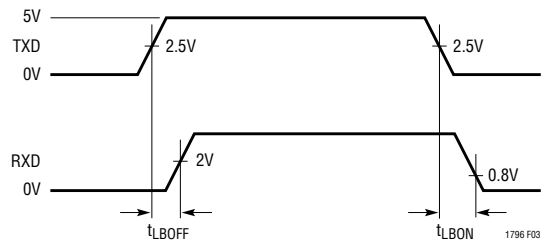

Figure 3. Loopback Delay Waveforms

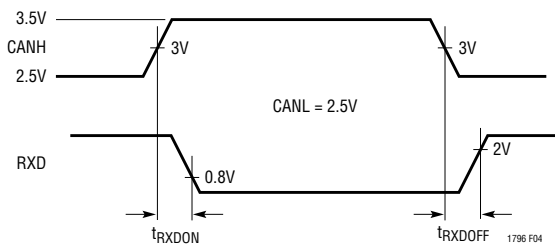

Figure 4. Receiver Delay Waveforms

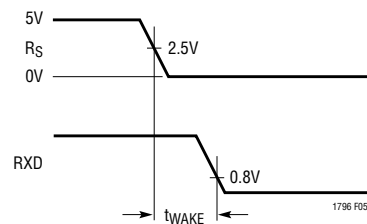

Figure 5. Wake Up from Standby Waveforms

## FUNCTION TABLES

### Driver Output

INPUTS		BUS TERMINALS		OPERATING STATE
TXD	RS	CANH	CANL	
0	$V_{RS} < 3V$	High	Low	Dominant
0	$V_{RS} > 4V$	Hi-Z	Hi-Z	Standby
1	$V_{RS} < 3V$	Hi-Z	Hi-Z	Recessive
1	$V_{RS} > 4V$	Hi-Z	Hi-Z	Standby

### Receiver Output

BUS VOLTAGE $V_{BUS} = V_{CANH} - V_{CANL}$	RS	RXD	RESPONSE TIME
$V_{BUS} < 0.5V$	<3V	High	Fast
$0.5V \leq V_{BUS} \leq 0.9V$	<3V	Indeterminate	Fast
$V_{BUS} > 0.9V$	<3V	Low	Fast
$V_{BUS} < 0.5V$	>4V	High	Slow
$0.5V \leq V_{BUS} \leq 0.9V$	>4V	Indeterminate	Slow
$V_{BUS} > 0.9V$	>4V	Low	Slow

# PACKAGE DESCRIPTION

Please refer to <http://www.linear.com/designtools/packaging/> for the most recent package drawings.

## N Package 8-Lead PDIP (Narrow .300 Inch) (Reference LTC DWG # 05-08-1510 Rev I)

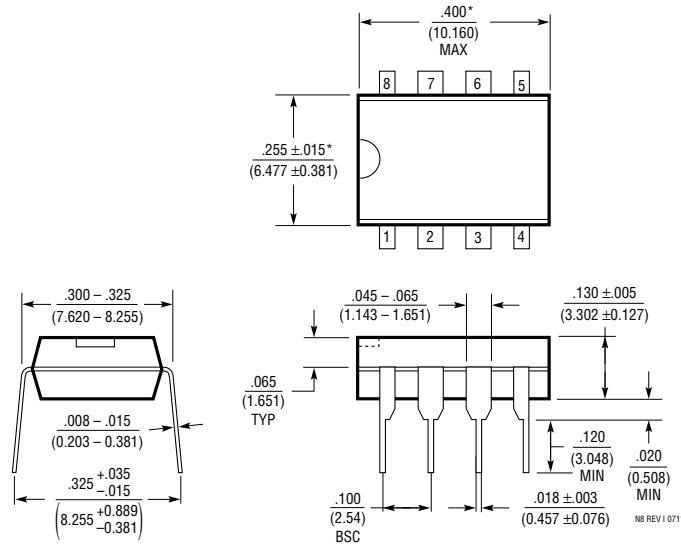

NOTE:  
1. DIMENSIONS ARE  $\frac{\text{INCHES}}{\text{MILLIMETERS}}$   
\*THESE DIMENSIONS DO NOT INCLUDE MOLD FLASH OR PROTRUSIONS.  
MOLD FLASH OR PROTRUSIONS SHALL NOT EXCEED .010 INCH (0.254mm)

## S8 Package 8-Lead Plastic Small Outline (Narrow .150 Inch) (Reference LTC DWG # 05-08-1610 Rev G)

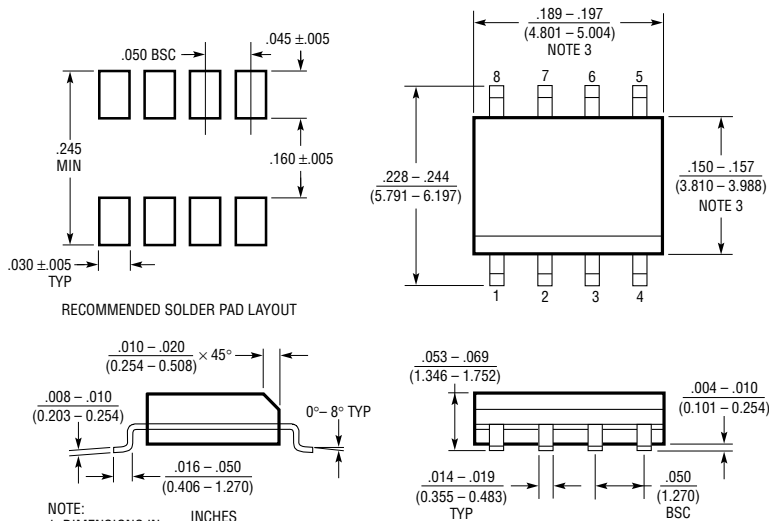

NOTE:  
1. DIMENSIONS IN  $\frac{\text{INCHES}}{\text{MILLIMETERS}}$   
2. DRAWING NOT TO SCALE  
3. THESE DIMENSIONS DO NOT INCLUDE MOLD FLASH OR PROTRUSIONS.  
MOLD FLASH OR PROTRUSIONS SHALL NOT EXCEED .006" (0.15mm)  
4. PIN 1 CAN BE BEVEL EDGE OR A DIMPLE

S08 REV G 0212

---

**REVISION HISTORY**

REV	DATE	DESCRIPTION	PAGE NUMBER
A	8/15	Increased $t_{TXDOFF}$ max limit	4

## TYPICAL APPLICATION

Low EMI, Slew Limited CANBUS Network

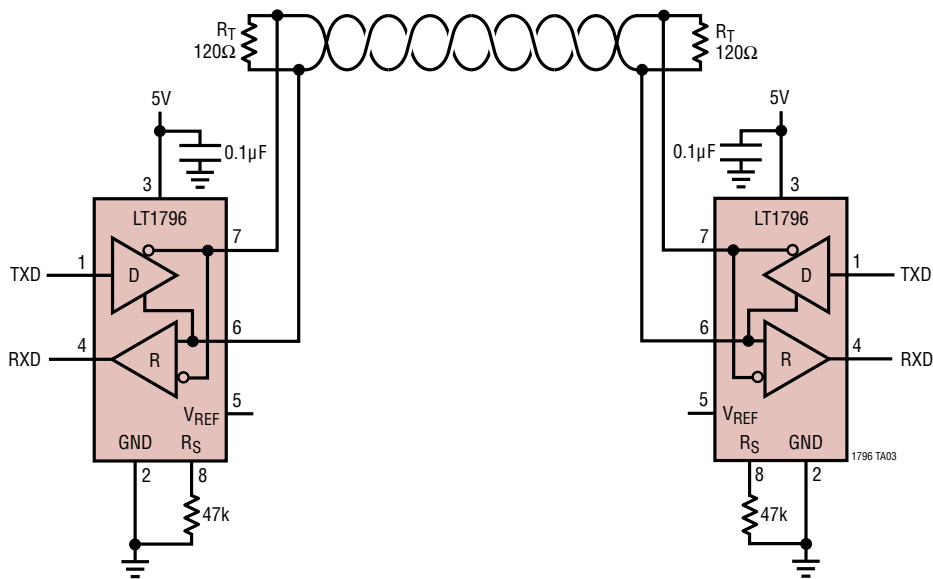

## RELATED PARTS

PART NUMBER	DESCRIPTION	COMMENTS
<a href="#">LTC485</a>	Low Power RS485 Interface Transceiver	$I_{CC} = 300\mu\text{A Typ}$
<a href="#">LTC491</a>	Differential Driver and Receiver Pair	$I_{CC} = 300\mu\text{A Typ}$
<a href="#">LTC1483</a>	Ultralow Power RS485 Low EMI Transceiver	Controlled Driver Slew Rate
<a href="#">LTC1485</a>	RS485 Differential Bus Transceiver	10Mbaud Operation
<a href="#">LTC1487</a>	Ultralow Power RS485 with Low EMI, Shutdown and High Input Impedance	Up to 256 Transceivers On the Bus
<a href="#">LT1785/LT1791</a>	60V Fault-Protected RS485/RS422 Transceivers	15kV ESD Protected
<a href="#">LTC2875</a>	$\pm 60\text{V CAN}$ Transceiver	3.3V or 5V Supply, 4Mbps Operation, 25kV ESD